

**30 AMP TRACK MOUNT CONTROL RELAY**

**RIBM243PN**

4.00" Track Mount Relay 30 Amp 3PDT with 24 Vac/dc Coil

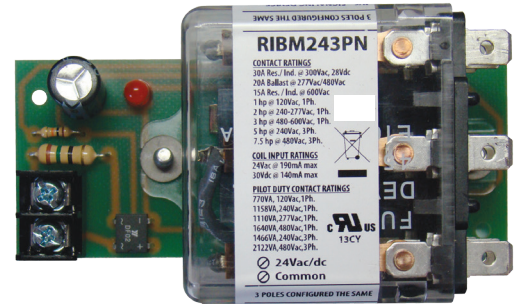
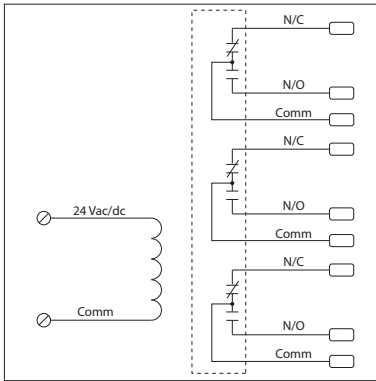

RELAYS

**SPECIFICATIONS**

**# Relays & Contact Type:** One (1) 3PDT Continuous Duty Coil  
**Expected Relay Life:** 10 million cycles minimum mechanical  
**Operating Temperature:** -30 to 140° F  
**Humidity Range:** 5 to 95% (noncondensing)  
**Operate Time:** 20ms  
**Relay Status:** LED On = Activated  
**Dimensions:** 2.450" x 4.000" x 1.750"  
**Track Mount:** 4.000", See MT4 Series on page 152  
**MT4 Mounting Track Sold Separately**  
**Approvals:** UL Component Recognized, UL916  
 C-UL, California State Fire Marshal  
**Gold Flash:** No  
**Override Switch:** No

**Contact Ratings:**  
 30 Amp General Use @ 300 Vac  
 30 Amp Resistive @ 28 Vdc  
 20 Amp Ballast @ 277-480 Vac  
*Not rated for Electronic Ballast*  
 15 Amp Resistive @ 600 Vac  
 7.5 HP @ 480 Vac, 3 Phase  
 5 HP @ 240 Vac, 3 Phase  
 3 HP @ 480-600 Vac, 1 Phase  
 2 HP @ 240-277 Vac, 1 Phase  
 1 HP @ 120 Vac, 1 Phase

Heavy Pilot Duty @ 600 Vac  
 770 VA @ 120 Vac, 1 Phase  
 1158 VA @ 240 Vac, 1 Phase  
 1110 VA @ 277 Vac, 1 Phase  
 1640 VA @ 480 Vac, 1 Phase  
 1466 VA @ 240 Vac, 3 Phase  
 2122 VA @ 480 Vac, 3 Phase

**Coil Current:**  
 190 mA @ 24 Vac  
 140 mA @ 30 Vdc  
**Coil Voltage Input:**  
 24 Vac/dc ; 50-60 Hz  
 Drop Out = 3 Vac / 3.8 Vdc  
 Pull In = 20 Vac / 22 Vdc